

# **PACKETIZED TELEMETRY INCREASES FEEDBACK SYSTEM RESPONSE TIME IN A HIGH ENERGY PHYSICS APPLICATION**

**Daniel “Shane” Woolridge  
Apogee Labs Inc.**

## **ABSTRACT**

A digital feedback system used to monitor and control a high energy electron beam's orbit and stability in a VUV and X-ray storage ring will realize a 10 fold increase in the feedback system response time using packetized (IRIG 107-98) telemetry. The improvement in feedback time will provide a significant improvement in the level of orbit stability.

This paper discusses the advantages of using a packetizing standard and high speed data acquisition as a cost effective way to support the scientific community in their real time processing needs.

## **KEY WORDS**

Synchrotron, Packetized Telemetry, Real Time Processing, Digital Feedback System, High Speed Data Acquisition.

## **INTRODUCTION**

The National Synchrotron Light Source (NSLS) building at Brookhaven National Labs contains two storage rings that produce synchrotron light, the Vacuum Ultra-Violet (VUV) ring and the X-ray ring. This paper will discuss the X-ray ring.

A synchrotron is a machine that guides a stream of charged particles such as electrons in an orbit. An electron gun shoots groups of electrons into a large circular tube called a storage ring, while powerful magnets help control the stability of the orbit. While in orbit, the electrons give off energy in various forms of light, including visible light, X-rays, ultraviolet, and infrared. This light is currently used for research in many fields of science including chemistry, physics, metallurgy, and biology.

A feedback system is put in place to provide the ability to monitor and correct the orbit of the electrons by controlling the electro-magnets.

## **CURRENT ANALOG FEEDBACK SYSTEM**

Beam Position Monitors (BPMs) are a very important part of the feedback system. Each BPM consists of four button Pick-Up Electrodes (PUE) embedded into the vacuum chamber around the circumference of the electron storage ring. An NSLS developed receiver processes the PUE button signals sequentially by time sharing a single amplifier and detector. The signals are switched to the amplifier by means of a single pole, four position, gallium arsenide commutating switch. The information from the BPMs is collected and transferred, in analog form, to multiple 12 bit analog to digital converters at the main VME control panel. Here, the signals must be filtered, AM detected, de-multiplexed and sampled by Track and Hold Amplifiers (THA) at a rate of 550 samples per second. All BPMs must be sampled at the same time so that accurate calculations may be made by the X-trim processor. Once this information is processed, simultaneous corrections to the position of the trim magnets are made by updating their voltage settings.

The existing analog feedback system has a quantity of only 16 Beam Position Monitors (BPMs) in the X-ray ring. Since studies have shown a significant reduction in orbit fluctuations at the locations of the BPMs, is desirable to include as many BPMs as possible.

The X-ray ring, the larger of the two rings, is 170 meters in diameter. The current analog system uses a large number of analog transmission lines, some of which are several hundred feet in length, in a high radiation environment. The result of this is induced noise that limits the accuracy of the signal to 10 usable bits.

## **PROPOSED APPLICATION CONCEPT**

There are many reasons for considering a digital feedback system. Increasing the number of BPMs would make the current analog system too complex. Additional BPMs can easily be added to a digital system. By digitizing the BPM output at the source with a 16 bit analog to digital converter, the signal will be less susceptible to induced noise, which will result in an improved beam position resolution of up to 14 usable bits. By using a high speed clock rate for the data transmission and acquisition, the bandwidth of the digital system will exceed that of the analog system.

Since the existing analog system has the sample timing set at the VME control rack, one obstacle to overcome is sending the sample timing to each A/D converter around the storage ring in the proposed distributed acquisition system. If a continuous stream of PCM data is sent from the A/D converters, additional cables would be needed to send the sample timing, which would result in an excessive quantity of transmission lines. Through the use of packetized telemetry, the sample timing can be sent to the A/D converter which can then respond with a burst of packetized data using the same transmission line. This half duplex configuration would reduce the amount of cables needed in the digital feedback system.

## USE OF STANDARDS

Packetized telemetry, as defined by the IRIG standard 107-98, allows multiple application processes to create units of data, called packets, that best suits each source. These packets may contain fixed or variable lengths of data recorded at fixed or variable intervals. By using this standard, the source data can be multiplexed and transmitted via high speed bursts. Data quality can be monitored by the VME control panel by observing the packet ID and packet sequence control provided in the source packet primary header. Figure A shows the source packet format:

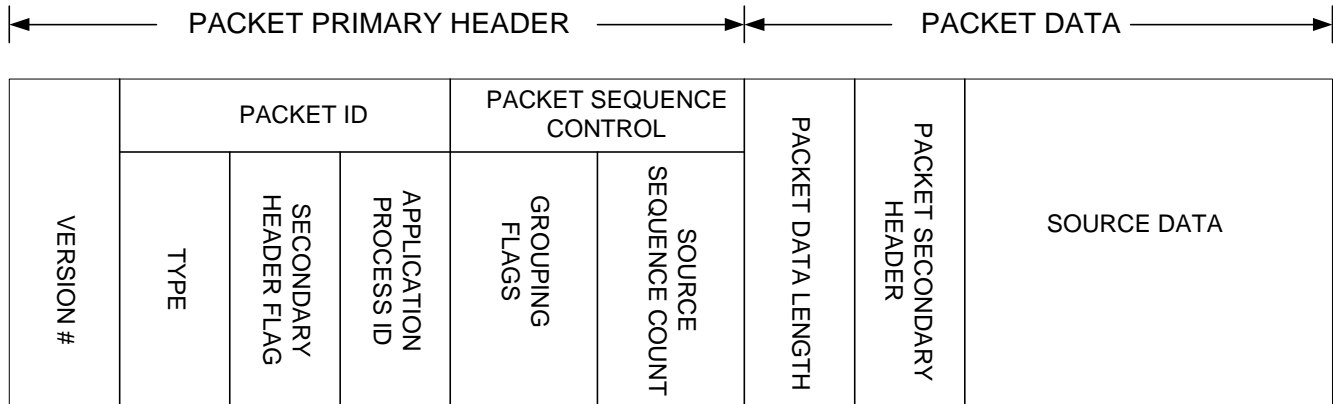

Figure A

## PROPOSED DIGITAL SYSTEM DESIGN

The need for additional BPMs is addressed by including a total of 48 pick-up electrodes. Each BPM has four signals from the PUE totaling 192 channels. Each signal will be digitized at the source by a low cost 16 bit A/D converter. The four signals at each PUE will then be easily multiplexed and packetized using a single inexpensive FPGA that only needs a serial prom and a low cost crystal oscillator to support it. The packets will contain a 6 byte header with 8 bytes of data, which includes four 16 bit words, one 16 bit word for each signal from a PUE. The A/D converter, multiplexer, and packetizer will be mounted at the location of the BPM in a small, shielded container to protect from noise caused by radiation. The high speed bursts of data will be sent to the VME control panel from each BPM by using a single line driver. The BPM analog signals will be A/D converted, multiplexed and packetized in 2.8 micro-seconds and de-multiplexed in 2 micro-seconds. The overall clock rate for transmission is 40 MHz. This enables all of the data to be collected in 5.6 micro-seconds.

At the VME control rack, a quantity of six VME de-multiplexer boards, with eight channels each, will use a very simple 8 channel x 4 measurement per BPM register file for VME read out. These boards will also be used to transmit the sample clock to the source. The sample clock is generated by the Apogee VME-CTI board, which generates the desired rate from IRIG-B time code, at a minimum rate of 4 kHz. After data collection, 235 micro-seconds is left for the X-trim micro to process the information and adjust the trim magnets, which is more than enough time for the existing processor and magnet trim control.

Figure B shows a block diagram of the proposed feedback system:

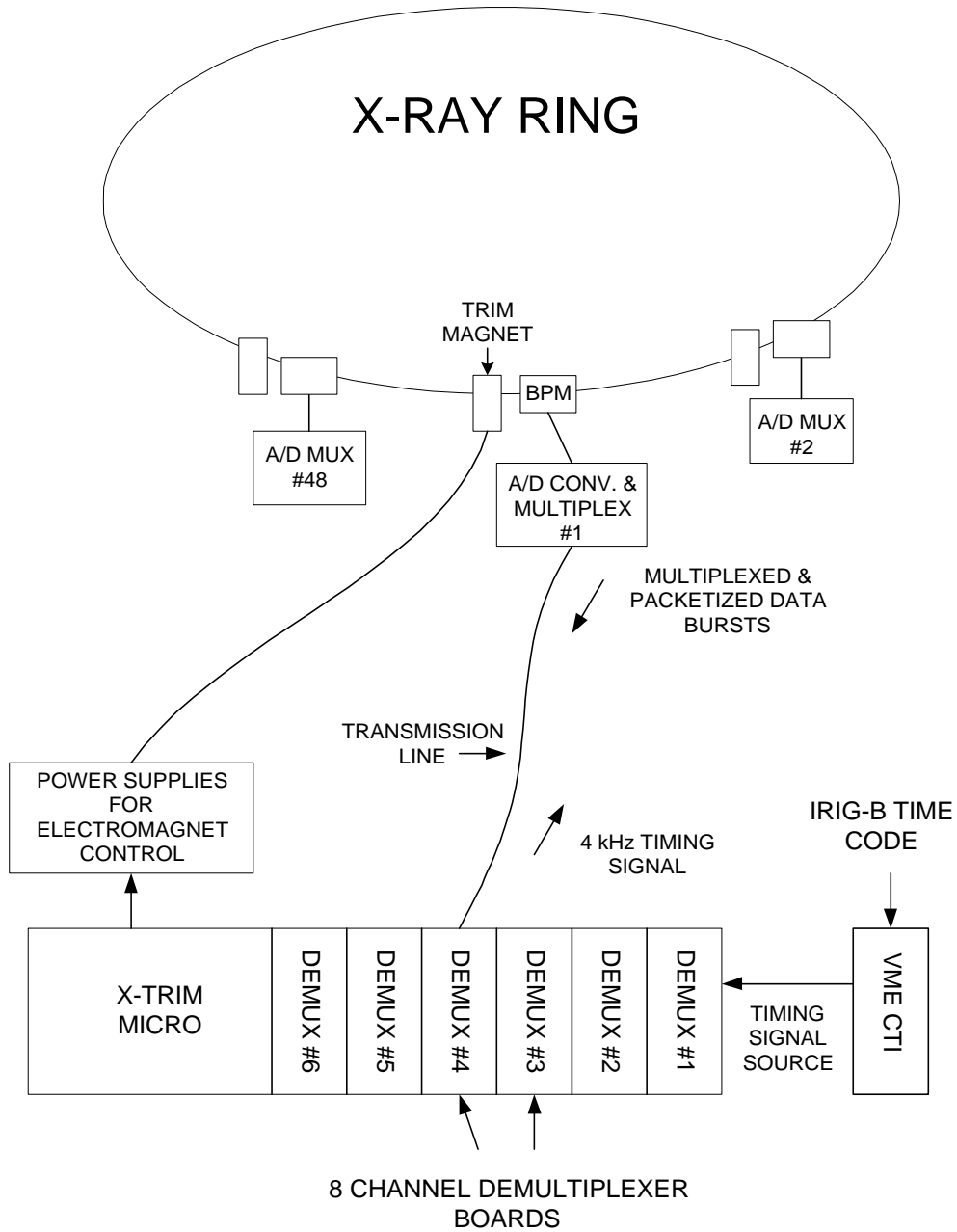

Figure B

## CONCLUSION

In summary, using packetized telemetry in a high speed data acquisition application has many advantages. An inexpensive digital feedback system can increase the number of BPMs while also increasing the response time and the bandwidth of the system. By digitizing at the source and increasing the rate of transmission, the sample timing was able to be increased to a minimum of 4 kHz. This is a 7.3 fold increase in response time, which is now limited by the application software. Even with the current software, it may be possible to increase the sample rate up to 6 kHz or even 8 kHz. The hardware has the ability to support a maximum sample timing rate of 66,000 samples per second.

## ACKNOWLEDGMENTS

The author wishes to thank Mr. John Smith at Brookhaven National Labs' National Synchrotron Light Source for his permission to use the feedback system at NSLS's X-ray ring as the example in this paper.

## REFERENCES

Telemetry Group Range Commanders Council, IRIG Standard 107-98, June 1998

R. Biscardi and J.W. Bittner, Proceedings 1989 IEEE Particle Acceleration. Conference, Chicago, IL, 1989, p. 1516

L.H. Yu, E. Bozoki, J. Galayda, S. Krinsky, G. Vignola, Nuclear Instrumentation And Methodology, A 284, 1989, 286

Y. Chung, G. Decker, K. Evans Jr., Particle Acceleration Conference, Washington DC, 1993, p. 2263

A. Friedman, E. Bozoki, Nuclear Instrumentation And Methodology, A 344, 1994, 269.

O. Singh, Y. Tang, S. Krinsky, Nuclear Instrumentation And Methodology, A 418, 1998, 267

Brookhaven National Lab web site for National Synchrotron Light Source [www.nsls.bnl.gov](http://www.nsls.bnl.gov)