

# **RECORDERS IN NETWORKED DATA ACQUISITION SYSTEMS**

**By David L Grebe  
Apogee Labs Inc.**

## **ABSTRACT**

The role of recorders in telemetry applications has undergone many changes throughout the years. We've seen the evolution from multi-track tape to disk to solid state technologies, both for airborne and ground based equipment. Data acquisition and collection system design has changed as well and a recent trend in airborne is to merge acquisition and recording. On the ground, increased decentralization of data collection and processing has generated the requirement to provide backup storage to protect against communication circuit outages.

This paper explores the trend to adopt network based data acquisition, collection, and distribution systems for telemetry applications and the impact on recording techniques and equipment. It shows that in this emerging approach the recorder returns to its' root mission of attempting to provide the fastest, largest capacity for the least amount of investment. In a network based architecture the recorder need only accept data and reproduce data and operates independently from the acquisition process.

## **KEY WORDS**

Networks, protocol layering, bridges, file servers, and recorder.

## **INTRODUCTION**

Fiscal pressures and technology requirements are accelerating the adoption of network based data acquisition architectures. This is true in both airborne platforms and ground support equipment.

In the air there are requirements of sufficient complexity and / or bandwidth requirement where a network based implementation becomes important. Fiber Channel for example, provides about 4000 times the bandwidth of 1553 and allows for extensions by adding new devices to the network much like adding peripherals to computers.

On the ground the world wide emergence of data networks is pervasive and implemented in an increasing variety of services (read: capacity, cost, and function.) Leveraging this commercial capability of networks, associated equipment, and practices provide the advantages of lower development and

deployment costs, ease of upgrades and extensions, ability to link large geographical areas and to take advantage of decentralized, distributed data processing.

This paper addresses some of the issues involved with airborne and ground-based networking systems that lay the foundation for understanding the role of recording in this environment. Methodologies of a network based acquisition system are quite different from Time Division Multiplexing.

## **BACKGROUND**

Ask a group of Test and Evaluation (T&E) engineers to describe their dream acquisition system and it would probably sound like this:

“a fast, scalable, inter-operable and time-coherent architecture with COTS-based interfaces that implement standards based protocols with a rich metadata infrastructure.” [1]

Well, maybe they would not use the term metadata! Each phrase in this example contains a mountain of assumptions, reveals frustrations with older technologies, and sets costing innuendoes. The term metadata refers to self-describing data. By adopting such a practice the data acquired can be routed to end users automatically without the need for preprocessing. It assumes sufficient resources are available to deliver this data when required. A master timing controller does not exist to specify exact transmission timing. If a master does exist its purpose is to control what process sources what data over the span of the mission. This means the system is scalable by inserting new nodes physically and logically into the architecture without impact to existing data sources or the transport and recording mediums.

Once a central control agency publishes a standard of data message structures then commercial manufacturers can produce interoperable equipment in a manner analogous to the World Wide Web application software and hardware. [2], [3] The software examples are programs like web browsers and email programs available from a variety of vendors that can work together. The hardware examples are the underlying network hardware: dial up modems, cable modems or satellite modems connected to network providers interconnected by carriers.

Implementing such an architecture using exchangeable hardware and software allows each application to take advantage of the best COTS solutions available without the need for ground-up system design each time a minor or major change is required.

On the ground side, the tracking facility requirements are reduced to providing the two way communication links and provide message routing and perhaps aggregation from multiple sources. The aggregating function is again an exercise in connecting COTS equipment that can ‘bridge’ the various hardware forms from which the data messages arrive. Any number of data links between facilities can be utilized as best suits the missions. Locally, point to point fiber, 100bT or Gigabit Ethernets can be interchanged. For longer distances ISDN, fractional T1, T1, bundled T1 (aka inverse multiplexing), T3, OC3, etc can be used. [4]

## NETWORKING ESSENTIALS

The flexibility and interoperability results from a layered architecture. Protocol layering is a technique to simplify designs by dividing them into functional layers, each concerned primarily with one task and defining protocols to perform each task. Each layer provides a well defined function while using a standards based interface to the layers above and below it. This means that each layer is independent of the others and therefore replaceable. For given applications, only the layers required need be assembled.

Protocols concern the formatting into and movement of Data Units and are illustrated in Figure 1. In this example, File Data is to be transferred between two computers (a peer-to-peer transfer functionally). In order to take advantage of an interconnecting network like the Ethernet and T1 infrastructure shown, the file must first be converted into Messages which the Host-to-Host peers know how to transfer, verify, and if required, retransmit. These messages then need to be placed into IP packets that the Inter-Net peers know how to move independently from the lower level physical link chosen. Note that along the path, the Ethernet link must transverse a T1 circuit, so a 'bridging' function partially disassembles the data and reformats it as required for T1 transmission. Note that all of this is transparent to the Process Layer.

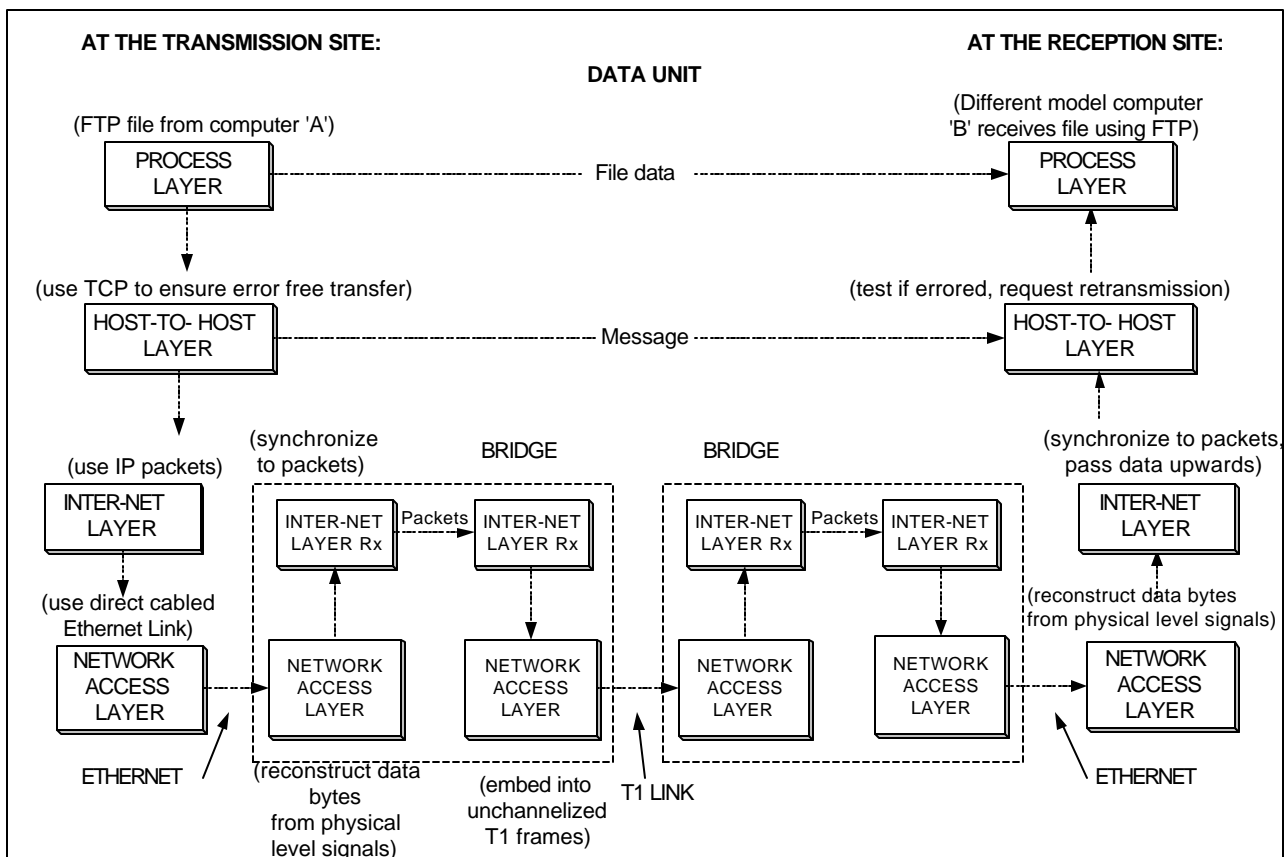

Figure 1: An example of Protocol Layering

Hardware is also an essential consideration as it relates to the physical ‘division of labor’ part of layering. A very modular system provides the greatest flexibility. However, embedding more than one layer’s processing/interconnects reduces hardware and therefore cost, size and power.

Nodes of a network typically exist to provide a Process Layer and are implemented by a computer or controller card. This means that intervening layers most often can be implemented in software that runs on the platform with only lowest level physical interface provided as ‘modular’ product.

While it is often possible to host several processes in the same node, there are instances where function-specific nodes stand out, for example: Printers and File Servers. These common elements of “networked computer systems” introduce the concept of Sharing. Resource sharing can provide telemetry applications with another advantage over previous approaches by eliminating duplication. Printers and file servers also illustrate different operating constraints that parallel air to ground transmitters and on board recorders. Printers need the entire Data Unit prior to initiating a print output (can’t intersperse print characters or lines.) The printer is basically a ‘fire & forget’ type interface with no feedback on success of operations beyond basic status. File servers on the other hand are typically designed to simultaneously read and write multiple files and thus support multiple logical connections at a time.

The last concept to overview is inter-networking which is concerned with connecting and moving Data Units among multiple and often different networks. If data is simply to be moved between networks without regard to filtering or getting involved with the exact path a Data Unit must take, the interconnecting device is a **BRIDGE**. It simply spans the gap between the two networks. If the networks are based on different protocols a **GATEWAY** node is required that decomposes and regenerates Data Units as required. A device that actively participates in routing the data between multiple networks or providing routing instructions throughout the network is a **ROUTER**. These elements will become more important as acquisition networks are more fully utilized in the air and the ground segments. One example is the use of a bridge to connect an operational Avionics network to a T&E acquisition system network.

## **RECORDER’S ROLE**

Figure 2 illustrates the use of recorders throughout a network based acquisition system. It expands the concept found in reference [5].

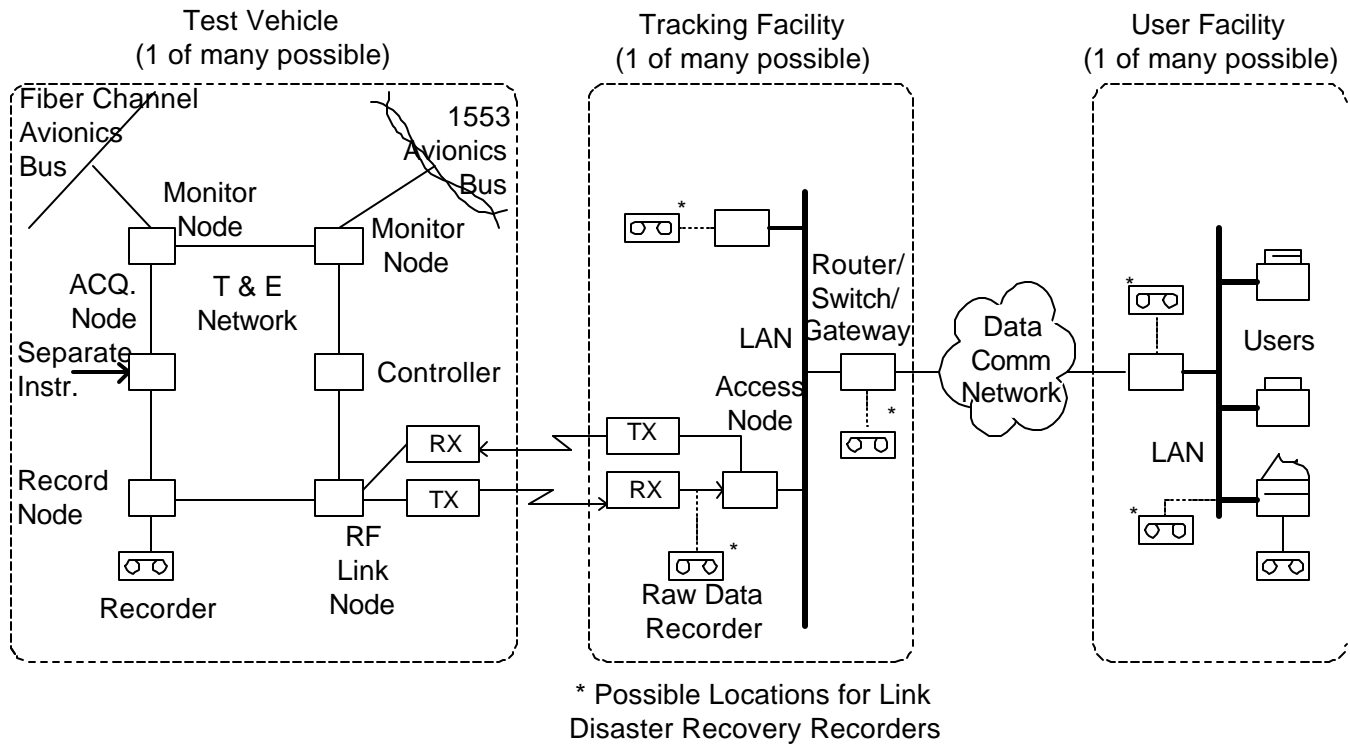

Figure 2: Network-Based Data Acquisition Overview

### Aircraft Network

Initially the record function seems simple: Record and Playback. However, just what data of all the network traffic is to be recorded? Since the network is NOT the acquisition process alone (network management data for example may also be present and the T&E network may be monitoring one or more production busses) it is not as simple as capturing all bus transfers. The recorder may be part of a store and forward process and needs to be able to simultaneously support both record and playback. Store and forward operations would support a reduced downlink TM bandwidth if vehicle maneuvering or loitering time could be used to off load the data. Another use of store and forward would be to implement a rate buffer. The data source of interest may produce more bits than the TM link can handle and a real time rate buffer using the recorder could address this problem.

So a clearer picture of the recorder may emerge by viewing its' function as a file server to which multiple processes are simultaneously connected. The connection itself is interesting as there are many possibilities. An acquisition process may be setup to direct all of it's output to the recorder (direct logical connection). But another alternative exists within a Publish/Subscribe environment. Data is "Published" onto the net by the acquisition node and multiple nodes such as a transmitter, another combining process, and the recorder "Subscribe" to this data (broadcast like connection.)

## Ground Network

If the vehicle under test is part of a network then the tracking site is no longer the primary data collection and processing site. Instead it may be viewed as a bridge or router within the overall network. Recording is therefore primarily geared to Data Link Disaster Recovery. There does not appear to be a “best” location or description of operation for recorders in this area. One option is to provide a dedicated recorder for each link input and record all of the transmissions received. The drawback to this is the loss of data time correlation between the separate recorders and the need for a recorder per link. Another option is a recorder that is part of the data aggregation process which can provide a copy of the composite data stream to maintain coherency. The drawback is that the recorder becomes a proprietary entity closely coupled to the data multiplexer supplier.

A third option is to develop a bus monitor interface that captures all outbound data and stores it separated by IP address for example. Then if the data needs to be retrieved, software can select the data packets of interest from the recording for retransmission. This would eliminate the confusion caused by attempting to place all of the recording session’s network traffic on the bus which is certain to contain control/response packets.

Training exercises can be facilitated when the composite data stream is recorded. When played back, the resulting composite stream from the tracking site would be indistinguishable from real time data if only streaming data is involved.

Issues involved also include link rates, mission duration and desired storage time. If bulk recording for archiving is the purpose then the storage medium (whether it is removable, storable or transportable) and its ability to be read at other locations are added requirements.

## Common Questions

The format of the data storage is often an issue associated with recorders. In the file server world, this may or may not be an issue. If all access of data is network based, there should be no more concern over the exact storage format or physical characteristics any more than the network’s physical link layers need to be known. At the Process Layer, the data Source and Sink know what the Data Unit is between them and that’s all they will ever see. However, if it must be required that recordings be read at other locations using another vendor’s equipment then both the physical and data format characteristics must be controlled. It is interesting to note then that the severity of the problem rests with the system designer and can be mitigated by providing network usage guidance that requires the adoption of the server paradigm. Alternately a ‘gateway’ or ‘bridging’ function between dissimilar recorders that are located around the same network can be used to translate the data but is cumbersome at best.

Data coherency relates to the ability to cross-correlate data from multiple sources during data analysis. In a network environment it is possible to assign priorities or quality of service values to time sensitive data to be sure it is serviced promptly. But it is not practical to implement a TDM like sampling plan as the means for establishing timing relationships. Rather, it will be up to each data source to imbed time within the Data Units. Smart sensors may provide compressed or pre-processed data which only the source can time tag. This needs to be considered when defining the Standard Message Formats to be

used within the network so that all processes can conveniently access and interpret the time data. Establishing a standard time format and methods of attaching the time to the data messages is quite a challenge for range applications. The time of first data receipt is only useable if the time interval between successive data in the message can be known. However that type of information may be better placed in the description or metafile data rather than occurring repeatedly in the Data Unit header. From this it can be seen that the recorder should not be involved with time tagging data as data structures will vary and data arrival time will not be uniform.

The amount of bandwidth both on airborne and ground local area networks is very high compared to the TDM output bandwidth of the past. This bandwidth however is likely to encounter bottlenecks between the data sources and sinks such as air to ground bandwidth allocation problems and the high costs of long distance high bandwidth carriers between sites on the ground. This is where recorders of large storage capacity can enable new techniques such as the rate buffer / store and forward operations previously described.

## SUMMARY

Moving into network based architectures will present new problems for recorder vendors but the base technologies of tape, disk, solid state memories, and optical mediums will each continue to find applications. The electrical interface between the drive and the acquisition system will be quite different from current devices but can be built on techniques already in place in commercial networking but with an eye towards miniaturization and modularity. Regardless of how the network is operated (data directed to the disk or 'broadcast' in a Publish/Subscribe manner) a network based interface to the recorder would remain the same. This is a key to achieving an extensible, real time re-configurable, advanced network based data acquisition system.

## REFERENCES

- [1] "Draft JDANS Vision Statement," Naval Air Warfare Center Aircraft Division, JDANS Conference, August 2001.
- [2] "Standard Message Home Page," 12 April 2002, <http://jdans.navair.navy.mil/StdMsg/>.
- [3] "Standards & Reports, CCSDS Library," 25 August 2001, [http://www.ccsds.org/document\\_access.html](http://www.ccsds.org/document_access.html).
- [4] Grebe, David L., "Test Range Data and Communication Networks: Packetized Telemetry Techniques Bridge the Gap," Proceedings of the European Telemetry Conference, Garmisch-Partenkirchen, Germany, May 27-30, 2002.
- [5] Chalfont, Timothy A. and Gurn, Richard, "Real-Time Telemetry Network," Proceedings of the International Telemetry Conference, 1998, pp 407-414.