



AL6301 DATA LINK TEST SET



FEATURES

- 17 Module Slots
- 105-230 VAC 47-63 Hz Power Input
- Typically < 15 lbs.
- 5.25" x 19" wide x 15.75" deep Rack mount or Standalone
- Bright LED Display Provides Wide Viewing Angle
- Ethernet Remote Control

Specific operational features depend upon the type of installed modules. The following list is representative of a typical Apogee Labs Data Link Test Module.

- BIT RATES from 100 bps to 35 Mbps
- Pseudo-Random Noise (PRN) patterns from 2^7-1 to $2^{31}-1$, forward and reverse
- User programmable PCM data stream
- TTL, RS422 and RS232 interfaces standard
- IRIG Code converter and Randomizer
- Programmable BLANKING feature to test modems and bit synchronizers
- Programmable ERROR insert
- Programmable DOPPLER Shift
- DATA LOGGING
- User Customized Measurement Display
- Testing based on ACCUMULATE, BIT PERIOD, or SECONDS
- Accepts external jittered transmit clock
- Selectable Data and Clock polarities, input and output
- Automatic receiver synchronization with PRN and PCM data
- TX and RX sync points on Rear Panel
- Chassis accepts up to 6 Data Link Test modules for multi channel testing
- Measurements include:
 - ⇒ Bits in Test
 - ⇒ Bits in Error
 - ⇒ Ones in Error
 - ⇒ Receive Re-sync (slips)
 - ⇒ Frames in Error
 - ⇒ Link Delay
 - ⇒ Received Bit Rate
 - ⇒ Bit Error Rate
 - ⇒ % Symmetry
 - ⇒ Bit Slip Probability
 - ⇒ Seconds in Error
 - ⇒ Seconds Counter
- Real Time Controls:
 - ⇒ Insert 1 error into TX data
 - ⇒ Force TX output to all zeroes
 - ⇒ Slip TX data 1 bit time
 - ⇒ Force RX to Resync
 - ⇒ Clear/Restart Measurement
 - ⇒ Freeze Display
 - ⇒ Measure Link Delay

PURPOSE

The AL6301 Data Transmission Test Set is a modular device that is designed to support the performance of bit error rate testing (BERT) on data links and devices such as PCM bit synchronizers and modems. Having been designed as a totally modular device based upon Apogee Labs multiplexer product line, the AL6301 supports the inclusion of several Data Link Test modules (up to 6) as well as our full line of AL4300 multiplex, demultiplex and data link modules.

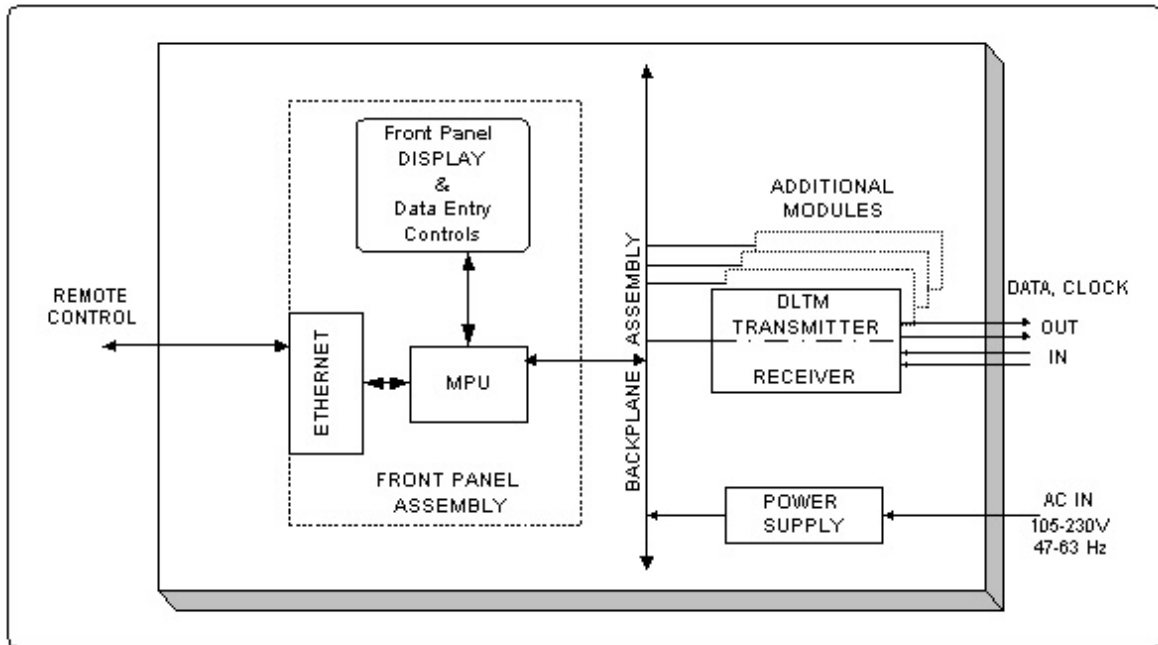

Figure 1: AL6301 Functional Block Diagram

SPECIFICATIONS

FRONT PANEL

High Contrast Luminescent Display
 Hex Numeric Keypad
 Cursor Control and Paging Key-Pad
 Four Soft Function Keys
 Six DLTM Sync Status Indicators

PHYSICAL

5.25" x 19" wide x 15.75" deep Rack Mountable
 17-Card Slots
 Plug-in Modules 4" High x 8" Deep
 Typically < 15 lbs.

ELECTRICAL

105-125 Vac, 47-63 Hz
 Typically < 200W

ENVIRONMENT

Operating Temperature - 0° to 40° C
 Altitude - Sea level to 15,000 ft

REMOTE CONTROL

10 baseT Ethernet
 ASCII coded Command / Response

COMPATIBILITY

DLTM Data Link Test Modules
 AL4300 / AL6300 Bus Compatible Support Modules
 Low Pass Filter
 Mixer
 Noise Generator
 PCM Bit Synchronizer
 Viterbi