

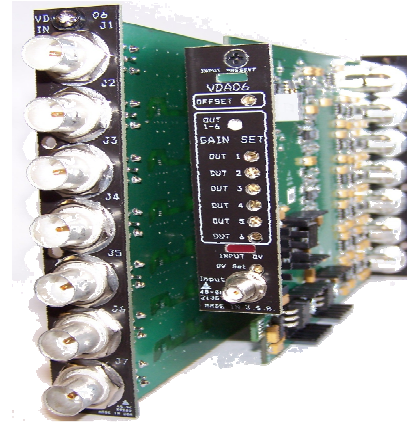

## VDA06 VIDEO DISTRIBUTION AMPLIFIER



### FEATURES

- One input on BNC connector
  - ◇ 1 V-rms nominal
  - ◇ 75Ω termination
  - ◇ Max input range  $\pm 15V$
  - ◇ Max input without damage  $\pm 15V$
  - ◇ DC offset control  $\pm 50\%$
- Six outputs on BNC connectors
  - ◇ 75Ω termination
  - ◇ 1 V-rms nominal
  - ◇ Unterminated output 10 Vp-p within  $\pm 5V$  range
- Individual output gain control
  - ◇ -10 dB to +15 dB with 1 V-rms nominal input
- Wide-band frequency response
  - ◇  $\pm 1$  dB, DC to 30 MHz
  - ◇  $\pm 1$  dB, DC to 30 MHz
- Harmonic distortion > 40 dB below rated output
- Noise floor > 60 dB below rated output
- Signal port return loss > 20 dB
- Channel to channel isolation
  - ◇ > 80 dB at 1 MHz
  - ◇ > 60 dB at 20 MHz
- Front panel indicators
  - ◇ Test point , isolated -20 dB of input
  - ◇ Over voltage LED with set point control
  - ◇ Signal present LED

### OVERVIEW

The Apogee Labs VDA06 is an Interfacer II module that is designed to accept a single wide-band signal and reproduce it on six independent gain controlled outputs. The module presents its controls and indicators and a test-point connector on its front panel. The signal input and six outputs are located on the module rear panel. All rear panel connectors are BNC type. The front panel connector is SMA type.

The user is given a front panel screw driver control for: input signal DC offset (BIAS) adjustment, over voltage (OVER) LED indication threshold by means of the SET adjustment, individual GAIN control for each of the six outputs, and an overall GAIN control. The presence of an input signal is indicated on an LED identified as PRES which is factory set at 400mV.

The AL2500 chassis accommodates up to 15 VDA06 modules. These modules are totally independent isolated video amplification functions. All controls and indications are located on the module front panel. The VDA06 does not support remote control operation.

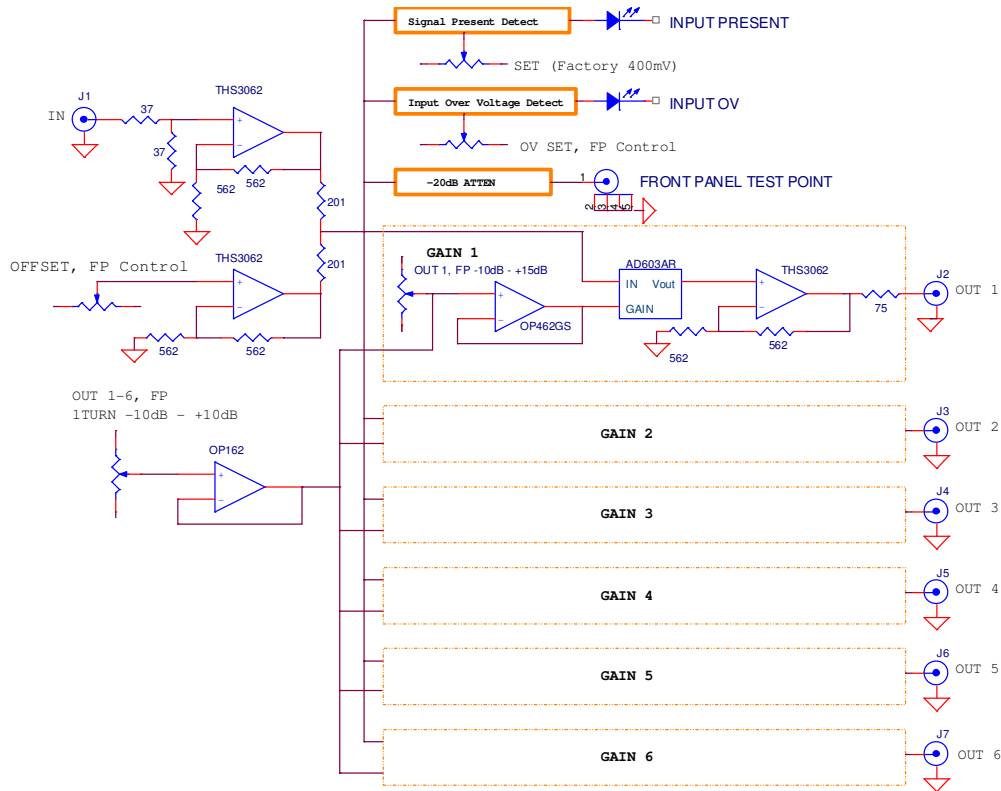

Figure 1 Video Distribution Amplifier (VDA06) Block Diagram

## SPECIFICATIONS

### GENERAL

- Single slot wide AL2500 module
- Up to 15 modules per chassis

### INPUT

- Input on one BNC connector
- 1 V-rms nominal
- 75Ω termination
- Max input range  $\pm 15V$
- Max input without damage  $\pm 15V$
- DC offset control  $\pm 50\%$

### OUTPUT

- Outputs on six BNC connectors
- 75Ω termination
- 1 V-rms nominal
- Unterminated output 15 Vp-p within  $\pm 10V$  range

### GAIN CONTROL

- Individual per output: -10 dB to +15 dB with 1 V-rms nominal input
- Master output (outputs 1-6): -10 dB to +10 dB from midpoint

### FREQUENCY RESPONSE

- Wide band
- $\pm 1$  dB, DC to 30 MHz;  $\pm 1$  dB, DC to 60 MHz

### HARMONIC DISTORTION

- > 40 dB below rated output

### NOISE FLOOR

- > 60 dB below rated output

### SIGNAL PORT RETURN LOSS

- > 20 dB

### CHANNEL TO CHANNEL ISOLATION

- > 80 dB at 1 MHz
- > 60 dB at 20 MHz

### FRONT PANEL INDICATORS

- Test point, isolated
- Over voltage LED with set point control
- Signal present LED

### TEST POINT

- SMA connector on front panel

### OPERATING TEMPERATURE

- 15° C to 50° C
- $\pm 1$  dB, DC to 30 MHz;  $\pm 1$  dB, DC to 60 MHz

### POWER CONSUMPTION

- 3.75 Watts