

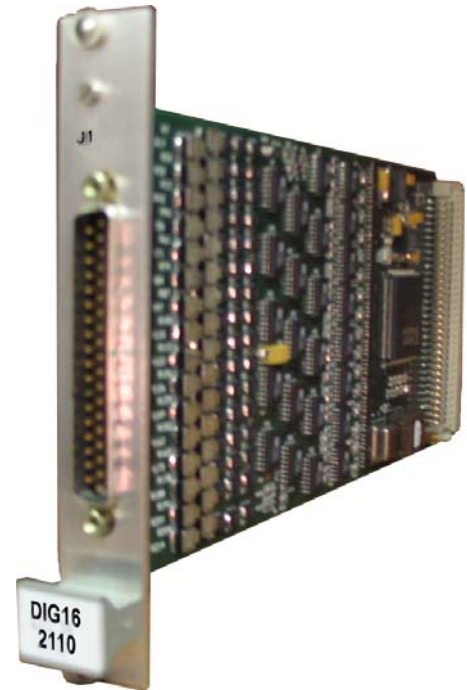

**MODEL 2110**  
**DIG16**  
**16-Channel Digital Discrete**  
**Input Module**



## 1. FEATURES

- **16 Discrete Inputs**
- **Hi-Z, Differential Inputs**
- **Level and Event Capture Modes**
- **±240 Overvoltage Protection**
- **Short and Open Conditions Detect**
- **±10 Volt Common Mode Offset Voltage**
- **±2.5V Digital On/Off Threshold**

## 2. OVERVIEW

This module accepts 16 discrete digital inputs, which can be any combination of Level and Event Capture modes. The resulting 16-bit word can be placed anywhere in the AL8400 PCM output stream. The level mode of operation simply inserts the level (1 or 0) of the input signal into its corresponding position in the PCM word at the time of word output.

In the Event Capture mode, each circuit recognizes a level transition which has occurred since the previous output and, if that new level persists for longer than 2  $\mu$ sec, captures the new 1/0 state for output at the next PCM word position available. After transmission, the capture circuit is reset and looks for the next transition.

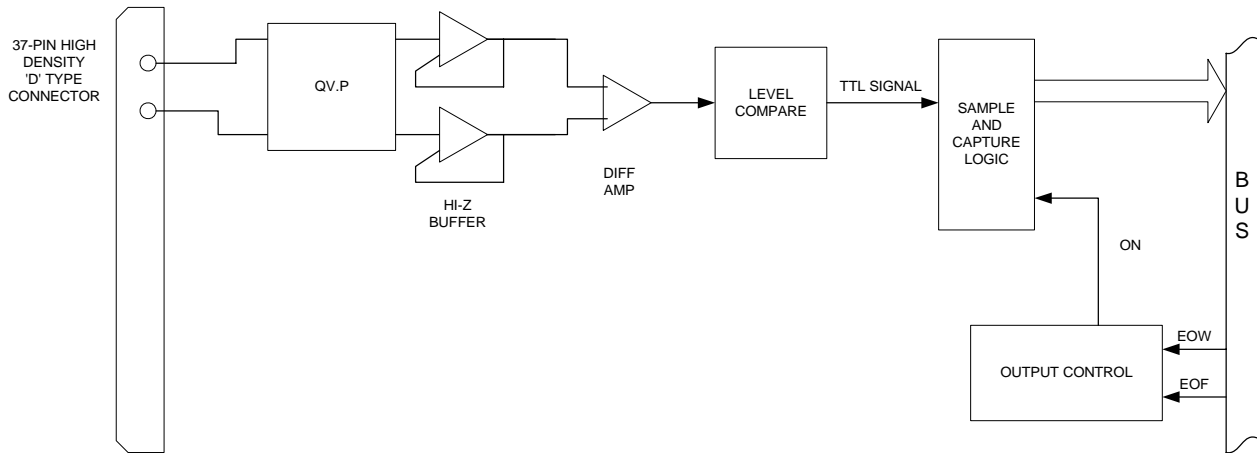

**Figure 1: Model 2110 DIG16 Block Diagram**

### 3. SPECIFICATIONS

#### GENERAL

Single Slot Module (3" x 6" x 0.9")

#### INPUT

High Density 37-pin 'D' Connector  
 16 Differential discrete inputs  
 Common-mode reference ground available  
 Chassis ground return provided

#### OUTPUT

±2.5 Volt Differential On/Off threshold  
 >2 µsec pulse detector  
 ±10 Volt Common-Mode range  
 ±240V Over-voltage protection

#### OPERATING TEMPERATURES

Operating Temperature Range of 0°C to 50°C

#### OPERATING HUMIDITY

80% relative humidity (rh) maximum,  
 15% rh, minimum

Apogee Labs Inc. products are sold by description only. Apogee Labs Inc. reserves the right to make changes in circuit design, software, hardware and/or specifications at any time without notice. Although Apogee Labs Inc. believes that the information provided is current and accurate, Apogee Labs Inc. does not assume any responsibility or liability for the use of any product described. It is the responsibility of the user to determine appropriate use of the product in any given application.