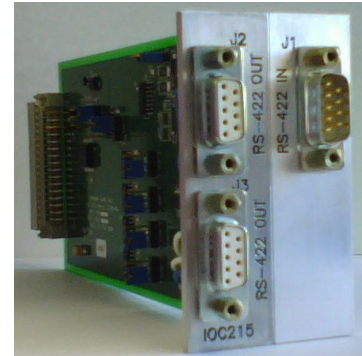

MODEL 2073 INTERFACER PRODUCT LINE

IOC215
RS-422 IN
TO
RS-422 OUT**FEATURES**

- One Independent RS-422 Level Input
 - One DB-9P Input connector
 - RS-422 Input Illuminates LED A on Front Panel
 - Selectable Input Termination (75 Ω or 120 Ω)
 - Input Drives Daisy Chain Bus A and Global Bus A
- Four Independent RS-422 Level Outputs
 - Two DB-9S Output Connectors
 - Independent Output Polarity Selection
 - High Current
 - Meets ANSI Standard for RS-422

OVERVIEW

The IOC215 Pluggable Interface Module (PIM) accepts one RS-422 Level input signal and produces four RS-422 level output signals. One RS-422 signal is input on a single DB-9P, buffered and reproduced times 2 and output on two DB-9S connectors. The maximum data rate for the IOC215 is 35Mbps. The RS422 input can also drive the daisy chain bus and the global bus in the Model 2073 Chassis, enabling the user to create additional copies of the two input signals. Output signal polarity is jumper configurable. The IOC215 requires two slots of the 14 available slots in the Model 2073 chassis.

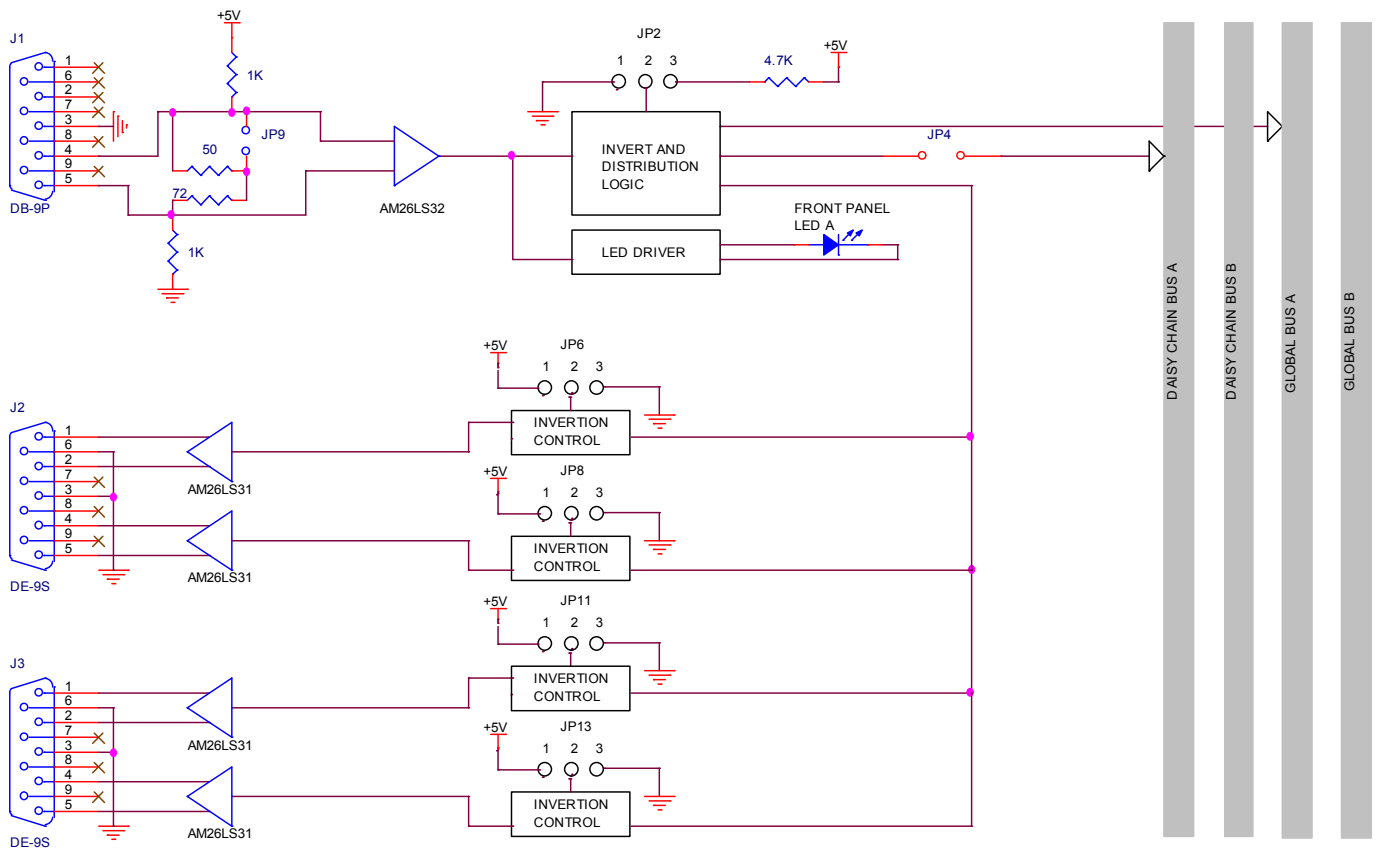

Figure 1: Model IOC215 Block Diagram

SPECIFICATIONS

GENERAL

- 1 Independent Input Channel
- 2 Slot Module (3" x 6" x 1.8")
- Model 2073 Pluggable Interface Module

OUTPUT

- Four RS-422 Level Outputs
- Two DB-9S connectors
- High Current
- Meets ANSI Standard for RS-422

INPUT

- One RS-422 Level Input
- One DB-9P connector
- 75Ω or 120Ω selectable termination

APPLICATION INFORMATION

The IOC215 is used to terminate and drive one RS-422 signals and produce two RS-422 signals.

This module can also be plugged into Apogee Models:

- 2907 and 2908: Data Acquisition Mux/Demux
- 6801: 5 Channel BERT Operation
- 6804: Multi Channel Clock Recovery

Apogee Labs Inc. products are sold by description only. Apogee Labs Inc. reserves the right to make changes in circuit design, software, hardware and/or specifications at any time without notice. Although Apogee Labs Inc. believes that the information provided is current and accurate, Apogee Labs Inc. does not assume any responsibility or liability for the use of any product described. It is the responsibility of the user to determine appropriate use of the product in any given application

Jumper	Assignment
JP2	Short 1-2, Normal Daisy Chain Bus A, Short 2-3, Invert Daisy Chain Bus A
JP4	Short to Drive Global Bus A with RS-422 IN
JP6	Short 1-2, Invert J2 Pins(1-2), Short 2-3, Normal J2 Pins(1-2)
JP8	Short 1-2, Invert J2 Pins(4-5), Short 2-3, Normal J2 Pins(4-5)
JP9	RS-422 Input A Termination – Open: 120Ω, Short: 75Ω
JP11	Short 1-2, Invert J3 Pins(1-2), Short 2-3, Normal J3 Pins(1-2)
JP13	Short 1-2, Invert J3 Pins(4-5), Short 2-3, Normal J3 Pins(4-5)